

Please check the examination details below before entering your candidate information

Candidate surname

Other names

Centre Number

Candidate Number

Pearson Edexcel Level 1/Level 2 GCSE (9–1)

Monday 19 June 2023

Morning (Time: 1 hour 45 minutes)

Paper
reference

1DT0/1B

Design and Technology
COMPONENT 1: Papers and Boards

You must have:

calculator, ruler, HB pencil, protractor, pair of compasses

Total Marks

Instructions

- Use **black** ink or ball-point pen.
- **Fill in the boxes** at the top of this page with your name, centre number and candidate number.
- Answer **all** questions.
- Answer the questions in the spaces provided
– *there may be more space than you need.*
- Calculators may be used.
- Any diagrams may NOT be accurately drawn, unless otherwise indicated.
- You must **show all your working out** with **your answer clearly identified** at the **end of your solution**.

Information

- The total mark for this paper is 100.
- The marks for **each** question are shown in brackets
– *use this as a guide as to how much time to spend on each question.*

Advice

- Read each question carefully before you start to answer it.
- Try to answer every question.
- Check your answers if you have time at the end.

Turn over ►

P71371A

©2023 Pearson Education Ltd.
N:1/1/1/1/



Pearson

SECTION A

Core

Answer ALL questions. Write your answers in the spaces provided.

- 1 (a) The materials that products are made from are chosen because of their properties.

Figure 1 shows a table of products.

For each of the products shown, give a property of the material it is made from that makes the material suitable for the product.

The first one has been done for you.



Picture of product	Material and product	Property
	Cotton T-shirt	Soft
	Polyester resin printed circuit board (PCB)	(1) (i)
	Balsa wood toy plane	(1) (ii)
	Stainless steel kitchen scissors	(1) (iii)
	Solid white board hardback book cover	(1) (iv)

Figure 1

DO NOT WRITE IN THIS AREA

DO NOT WRITE IN THIS AREA

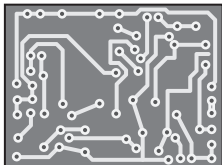
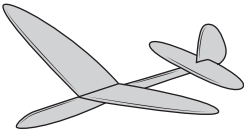
DO NOT WRITE IN THIS AREA

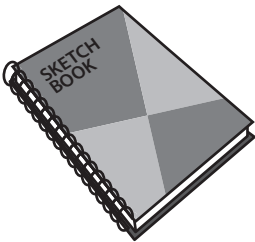

A printing company wants to use a new and emerging technology. It operates as a privately-owned business.

- (b) (i) Explain **one** advantage for the company of operating as a privately-owned business. (2)

.....

.....

.....

.....

The printing company has invested £150,000 of its own money to buy new and emerging technology but wants to raise an additional 30% by crowdfunding.

- (ii) Calculate how much additional money it will raise by crowdfunding. (2)

Answer £

(Total for Question 1 = 8 marks)



2 Figure 2 shows a concrete candle holder.

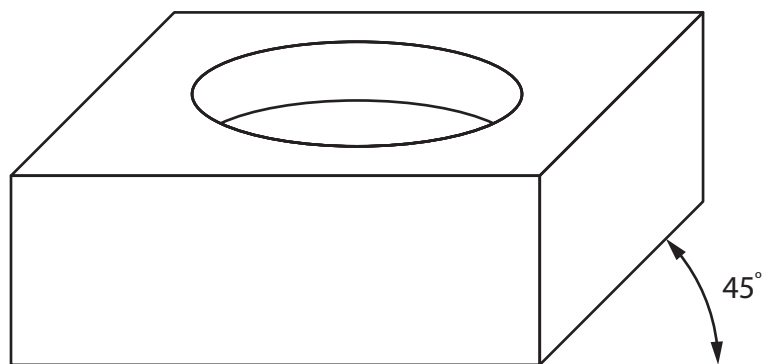

Figure 2

(a) Name the drawing method that has been used to show the concrete candle holder in Figure 2.

(1)

(b) Explain **one** reason for using concrete for the candle holder.

(2)



DO NOT WRITE IN THIS AREA

DO NOT WRITE IN THIS AREA

DO NOT WRITE IN THIS AREA

Figure 3 shows a standardised size of candle.

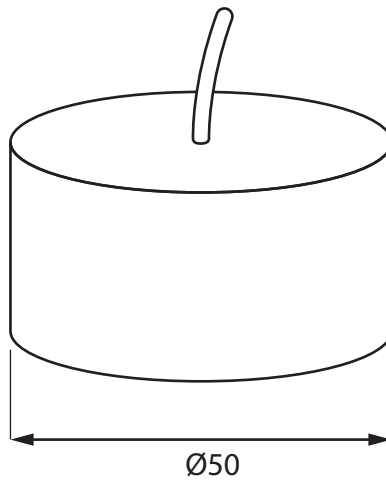

All dimensions in mm

Ø – diameter

Figure 3

(c) Explain **one** reason for manufacturing the concrete candle holder to hold a standardised size of candle.

(2)

.....

.....

.....



Figure 4 shows a dimensioned drawing of the concrete candle holder.

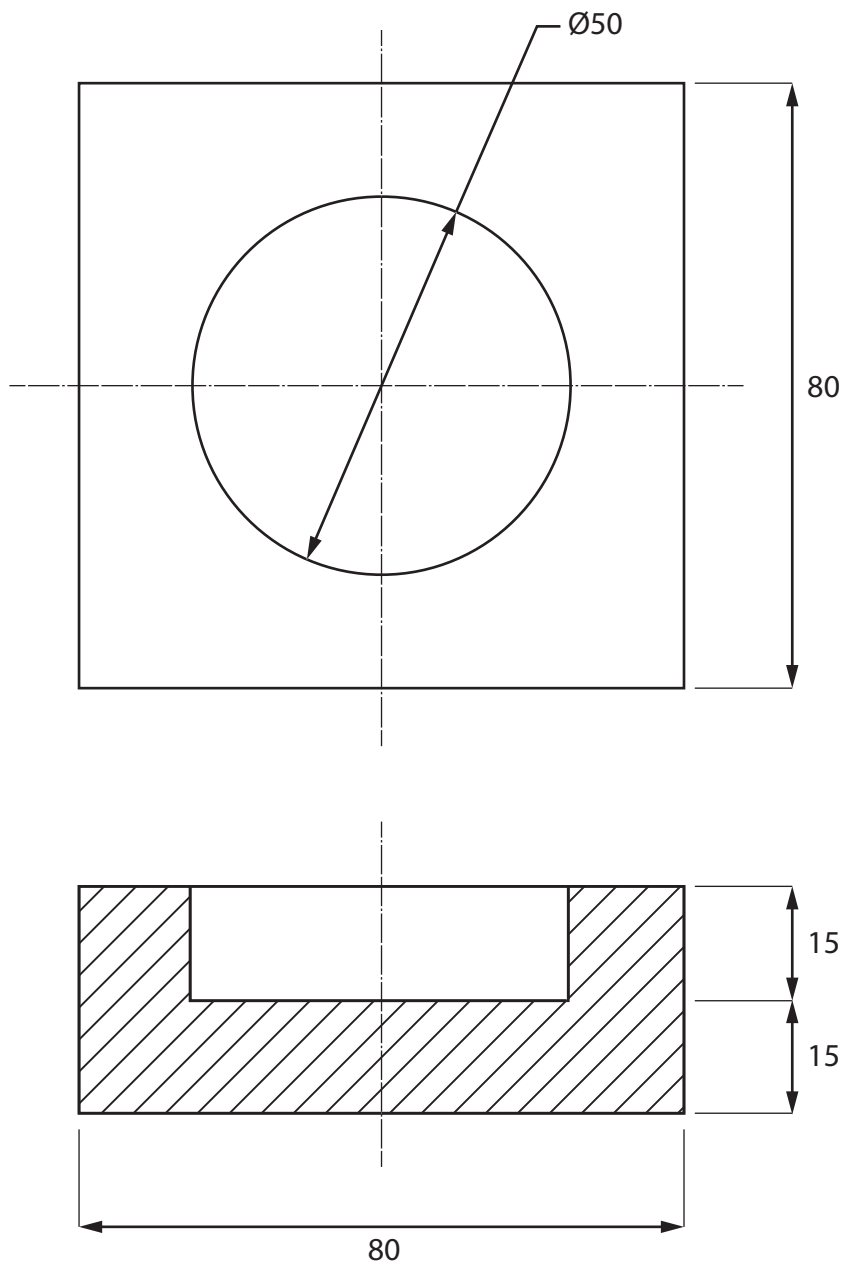

All dimensions in mm

Volume of cylinder = $\pi \times r^2 \times h$

Use $\pi = 3.142$

Figure 4



DO NOT WRITE IN THIS AREA

DO NOT WRITE IN THIS AREA

DO NOT WRITE IN THIS AREA

(d) Calculate the volume of concrete required to make the candle holder.

Give your answer in cm^3 to the nearest whole cm^3 .

(4)

Answer cm^3

(Total for Question 2 = 9 marks)



P 7 1 3 7 1 A 0 7 3 2

3 Figure 5 shows a vegetable growing frame that is manufactured from a softwood.

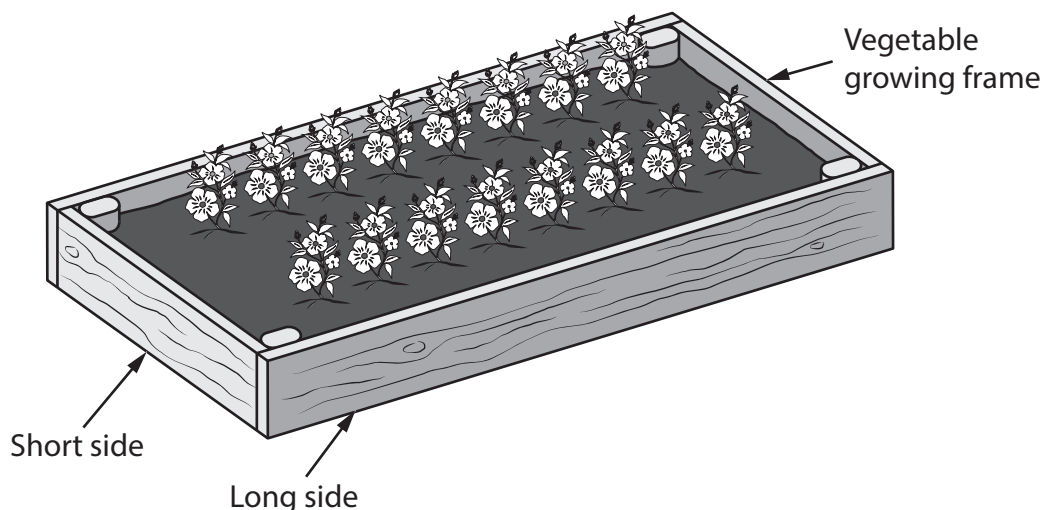

Figure 5

(a) Name **one** softwood that can be used to manufacture the vegetable growing frame.

(1)

(b) Explain **one** reason for manufacturing the vegetable growing frame from a softwood rather than a hardwood.

(2)

The original length of timber that is used to make the frame is 300 cm.

The combined length of one short side and one long side of the frame is 270 cm.

(c) Calculate how much timber is left when a short side and a long side have been cut to size, giving your answer as a fraction of the original length of timber.

Ignore the width of any saw cuts.

(2)

Answer



Figure 6 shows a mild steel fixing that has been used to join the vegetable growing frame together at the corners.

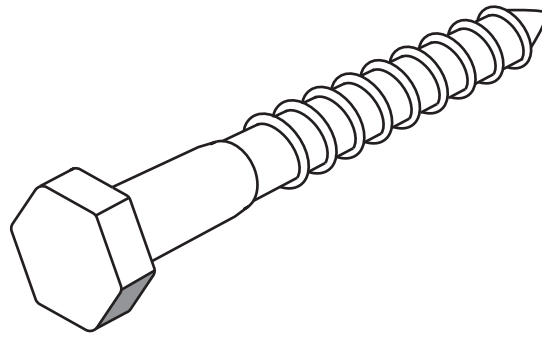

Figure 6

(d) Explain **one** disadvantage of using mild steel for the fixing.

(2)

.....
.....
.....

The vegetable growing frame is delivered in a box manufactured from corrugated board.

(e) Explain **two** benefits of using corrugated board to manufacture the box.

(4)

1
.....
.....
2
.....
.....

(Total for Question 3 = 11 marks)



4 Figure 7 shows a polyester laptop bag.



Figure 7

(a) Explain **one** working property of polyester that makes it an appropriate choice of material to make the laptop bag.

(2)

.....

.....

.....

.....

(b) The material for the laptop bag is 60% new polyester and the rest is recycled polyester.

The laptop bag requires 320 grams of polyester in total.

Calculate how many grams of recycled polyester are required for the laptop bag.

(2)

Answer grams



DO NOT WRITE IN THIS AREA

DO NOT WRITE IN THIS AREA

DO NOT WRITE IN THIS AREA

(Total for Question 4 = 12 marks)

TOTAL FOR SECTION A = 40 MARKS



DO NOT WRITE IN THIS AREA

DO NOT WRITE IN THIS AREA

DO NOT WRITE IN THIS AREA

BLANK PAGE
SECTION B BEGINS ON THE NEXT PAGE.



SECTION B

Papers and boards

Answer ALL questions. Write your answers in the spaces provided.

- 5 Figure 8 shows a design solution for a display stand to hold three boxes of chocolates together with some additional information.

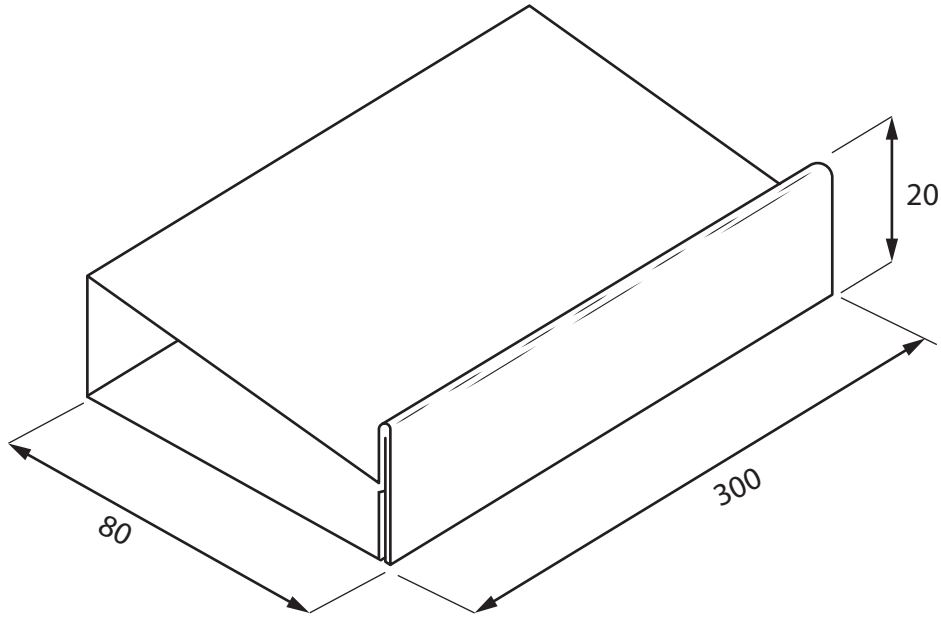

Additional information – dimensions of box of chocolates

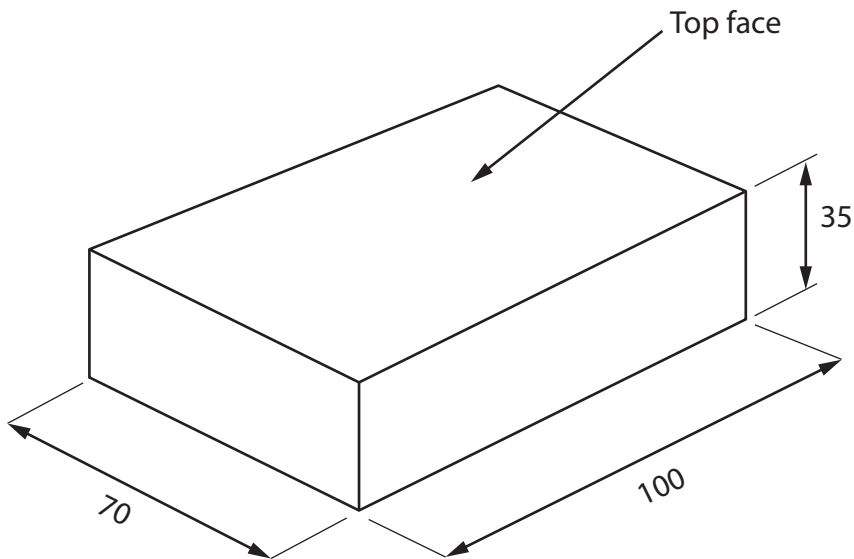

All dimensions in mm

Figure 8

DO NOT WRITE IN THIS AREA

DO NOT WRITE IN THIS AREA

DO NOT WRITE IN THIS AREA



- (a) The display stand holds three boxes of chocolates and needs to be improved to include the following specification points.

The display stand must:

- be able to hold an additional three boxes of chocolates and allow the top face of each individual chocolate box to be seen
- include a method to show the price of a box of chocolates that allows the price to be changed
- be portable so that it can be moved to another place without the chocolate boxes falling off.

Use notes and sketches to show how the display stand could be modified to include these three specification points.

You will be marked on how you apply your understanding of design and technology, not your graphical skills.

Use the outline of the original design solution to show your modifications.

(6)

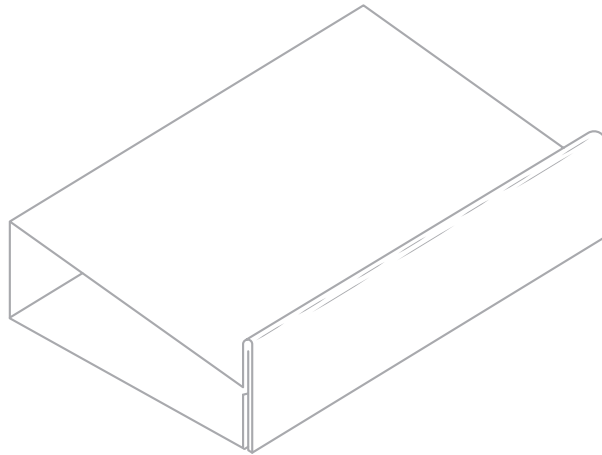

(b) Figure 9 shows a cardboard puzzle that is used to help develop hand-eye coordination in young children.

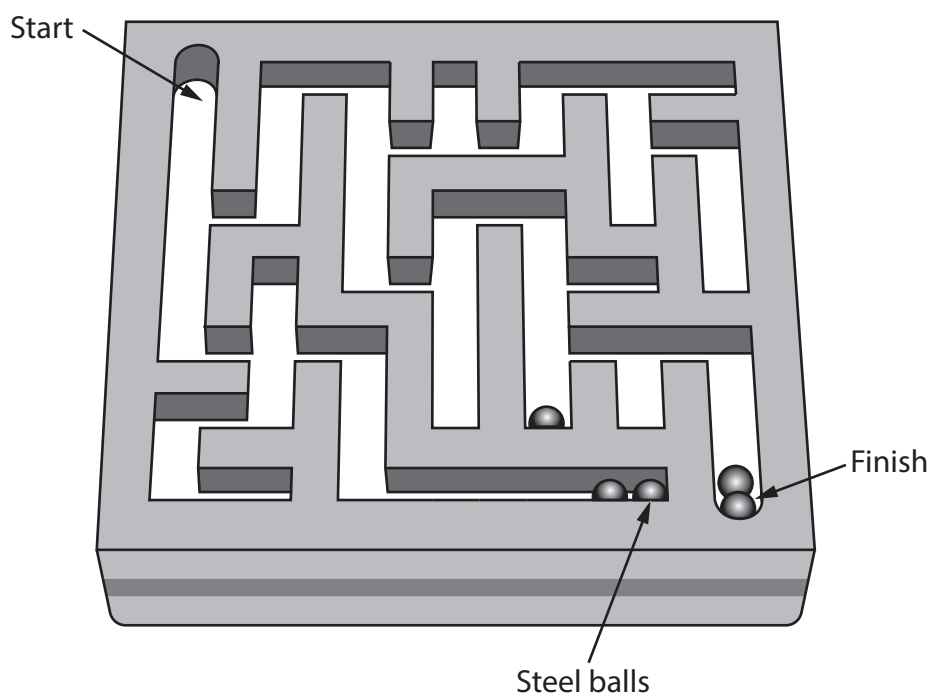

Figure 9

Explain **two** ways that the cardboard puzzle meets, or fails to meet, the criterion of providing a method to help develop hand-eye coordination in young children.

(4)

1

.....

.....

.....

2

.....

.....

.....

(Total for Question 5 = 10 marks)

DO NOT WRITE IN THIS AREA

DO NOT WRITE IN THIS AREA

DO NOT WRITE IN THIS AREA



(b) Figure 11 shows the net for the base section of the packaging marked out on a piece of folding boxboard.

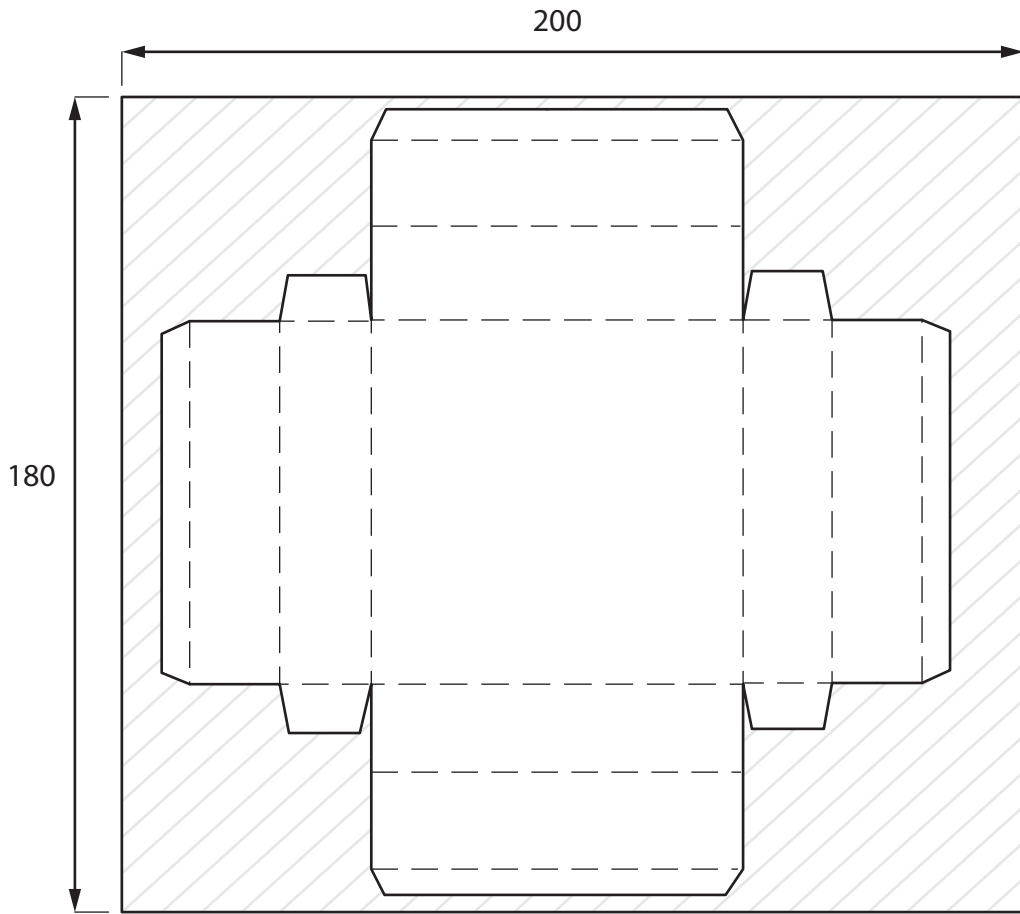

Key
——— Cut line
- - - - - Fold line

All dimensions in mm

Figure 11



Use notes and sketches, in the space below, to show how one base section of packaging would be cut out and assembled using hand tools.

You will be marked on how you apply your understanding of design and technology, not your graphical skills.

(4)

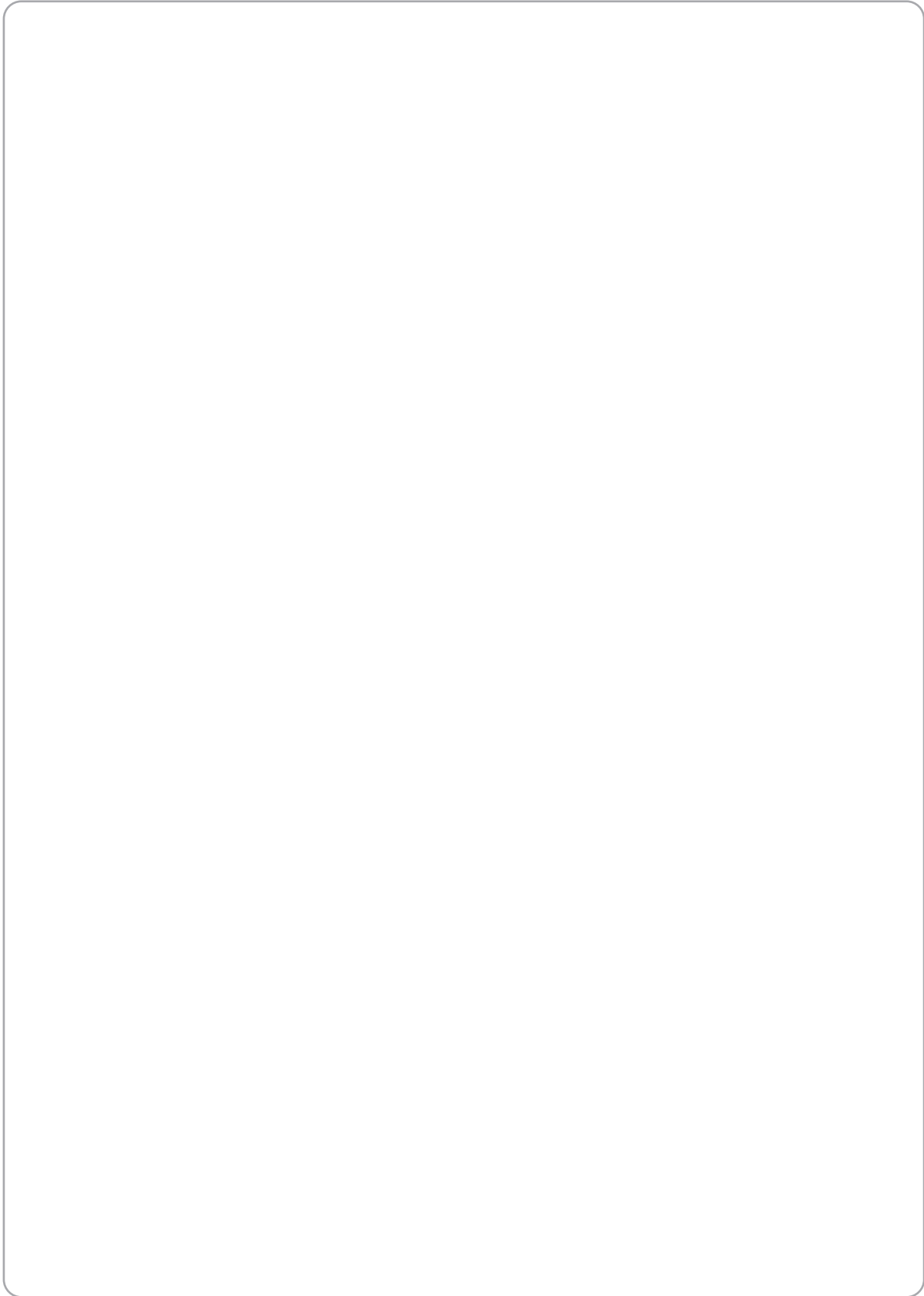

DO NOT WRITE IN THIS AREA

DO NOT WRITE IN THIS AREA

DO NOT WRITE IN THIS AREA



P 7 1 3 7 1 A 0 1 9 3 2

(c) Explain **one** way that the manufacturer of the packaging can avoid causing offence to potential buyers of the electronic device in different countries.

(2)

.....

.....

.....

.....

(d) A batch of 1000 nets for the packaging needs to be cut out from flat board.

Give **two** different manufacturing methods that could be used to cut out the nets.

Explain **one** reason for using each manufacturing method.

(6)

Method 1

.....

Explanation

.....

.....

.....

Method 2

.....

Explanation

.....

.....

.....

(Total for Question 6 = 16 marks)



DO NOT WRITE IN THIS AREA

DO NOT WRITE IN THIS AREA

DO NOT WRITE IN THIS AREA

BLANK PAGE
QUESTION 7 BEGINS ON THE NEXT PAGE.



P 7 1 3 7 1 A 0 2 1 3 2

7 Figure 12 shows a cardboard toy that is manufactured in a batch of 100 and a fastener that is used in the assembly of the toy.

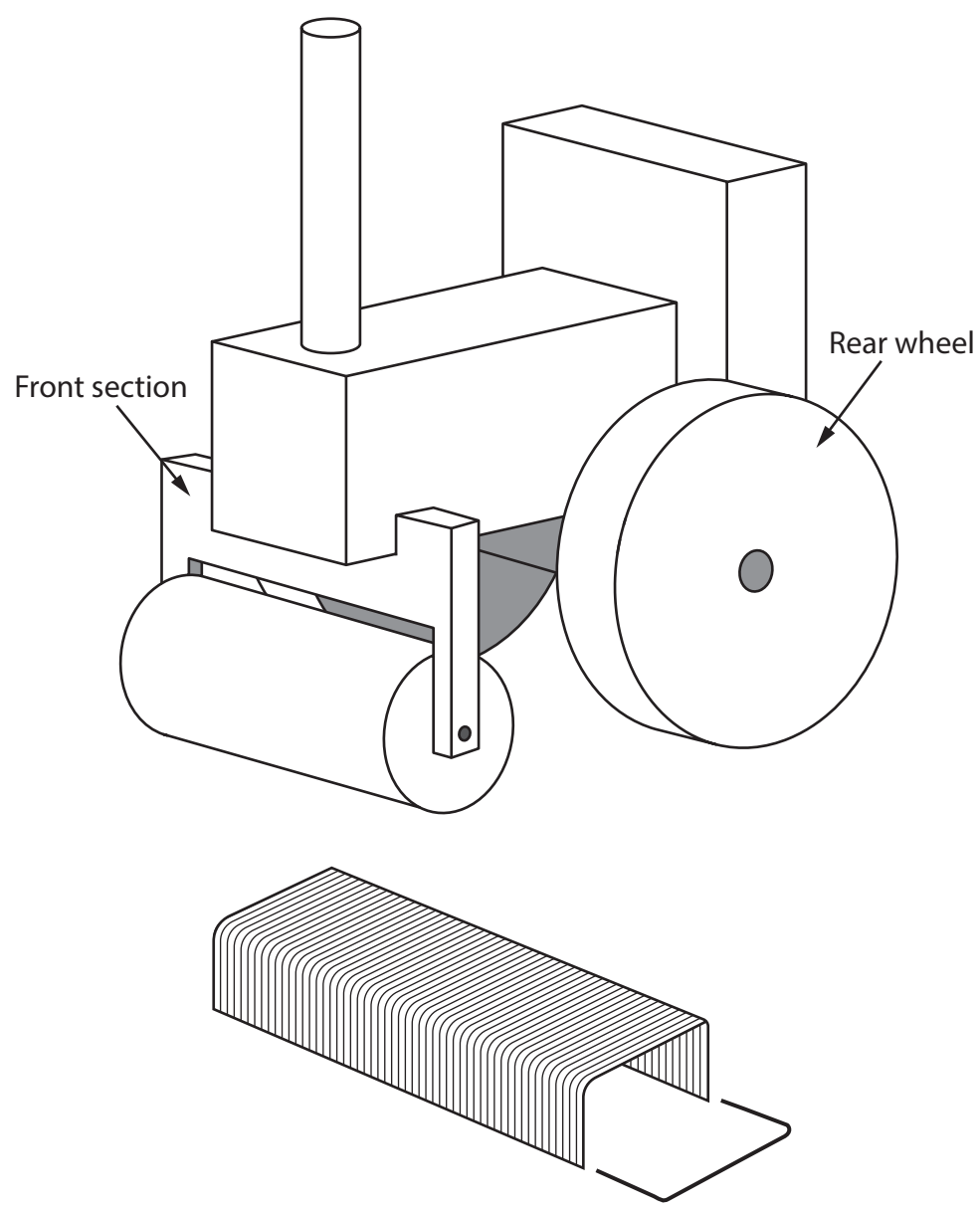

Figure 12

(a) Name the specific type of fastener shown in Figure 12.

(1)



Figure 13 shows the rear wheel of the toy which has been made from 6 mm thick corrugated board using computer-aided manufacturing (CAM).

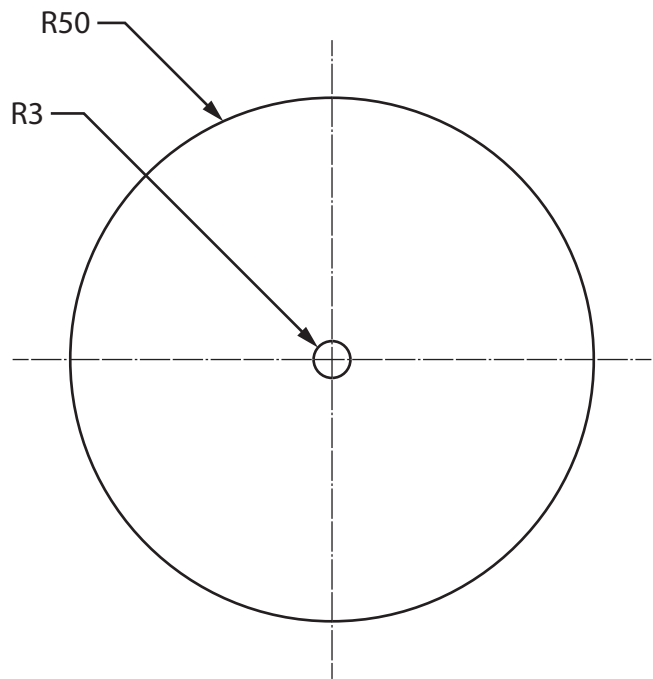

All dimensions in mm

Figure 13

(b) Explain **two** advantages of using CAM to manufacture the rear wheels of the toy.

(4)

1

.....

.....

.....

2

.....

.....

.....



P 7 1 3 7 1 A 0 2 3 3 2

(c) Figure 14 shows a dimensioned drawing of a template for the front section of the toy.

The template will be used to mark out the front section of the toy and will be made from 5 mm thick material.

Produce an isometric drawing of the template on the grid provided.

(5)

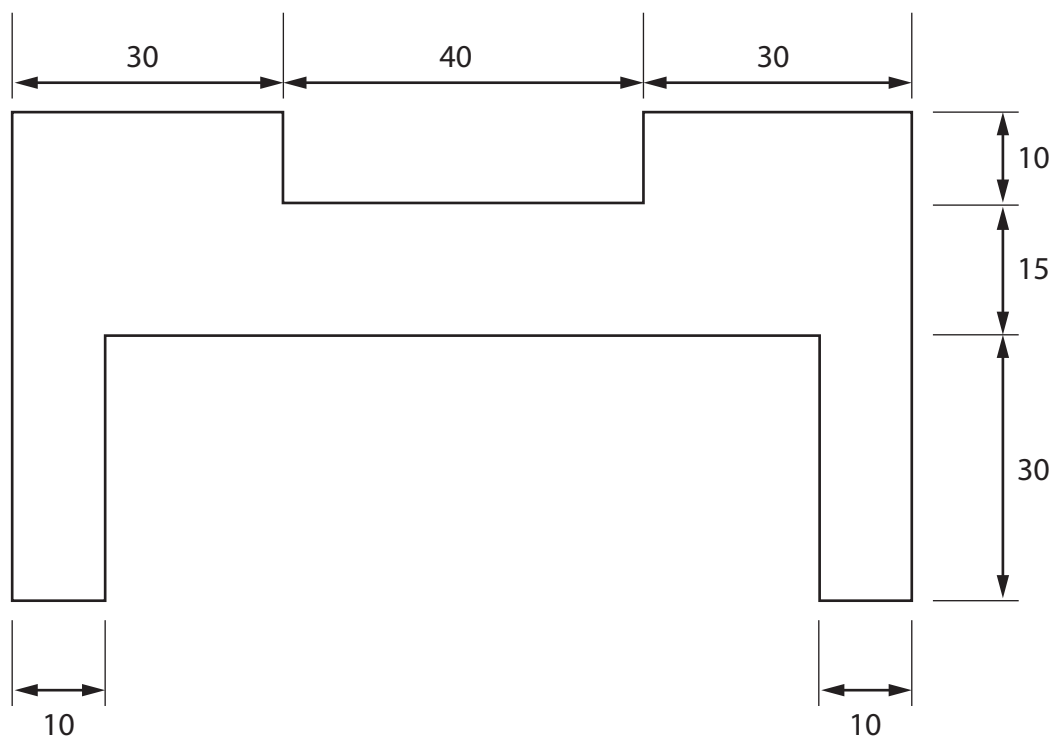

All dimensions in mm

Diagram not to scale

Figure 14



DO NOT WRITE IN THIS AREA

DO NOT WRITE IN THIS AREA

DO NOT WRITE IN THIS AREA

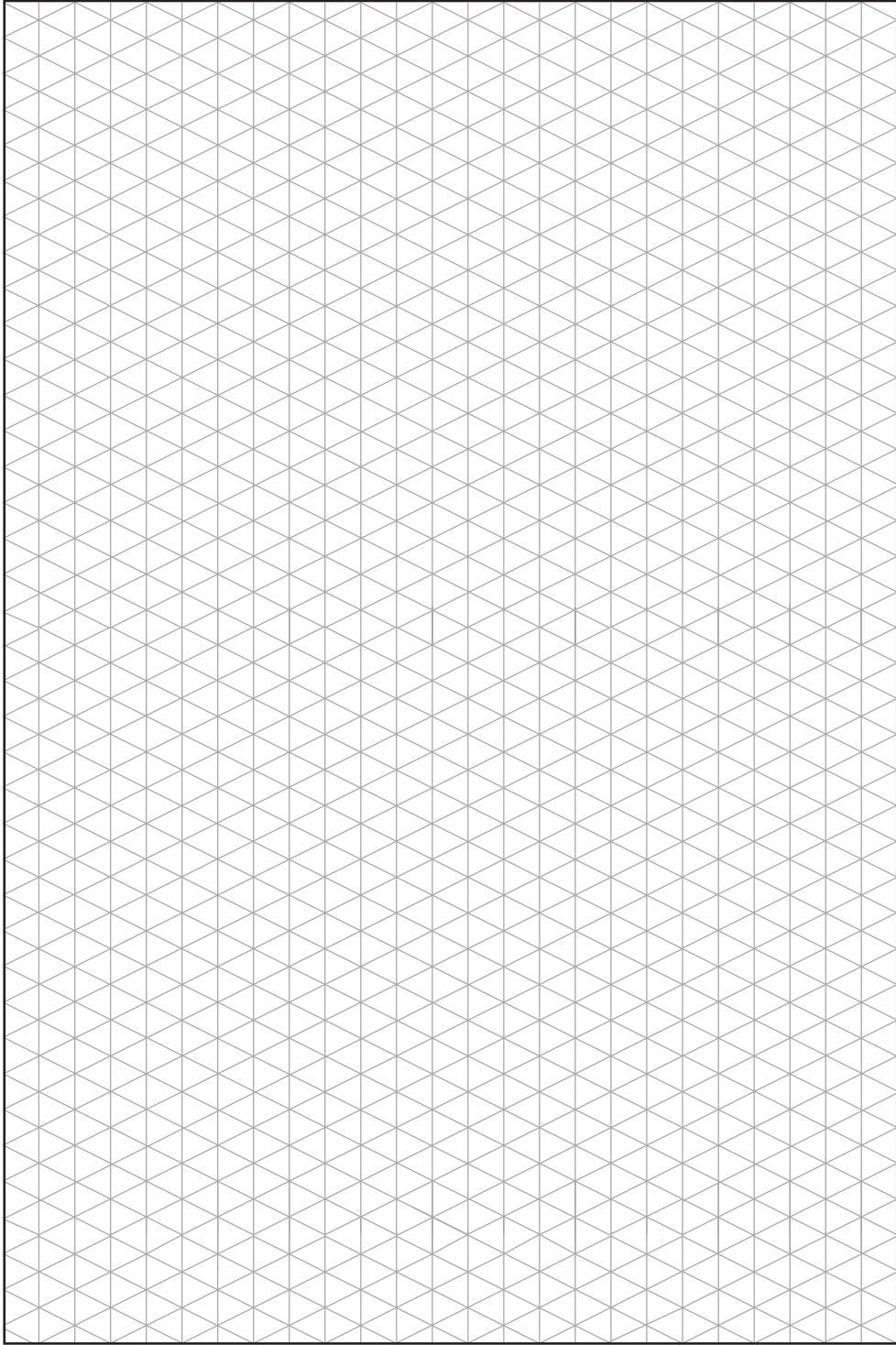

5 mm isometric grid



(d) Explain **two** disadvantages of using a template to mark out the front section of the toy.

(6)

1

.....

.....

.....

.....

.....

2

.....

.....

.....

.....

.....

(Total for Question 7 = 16 marks)

DO NOT WRITE IN THIS AREA

DO NOT WRITE IN THIS AREA

DO NOT WRITE IN THIS AREA



8 Figure 15 shows some takeaway food boxes manufactured from foil-lined board.

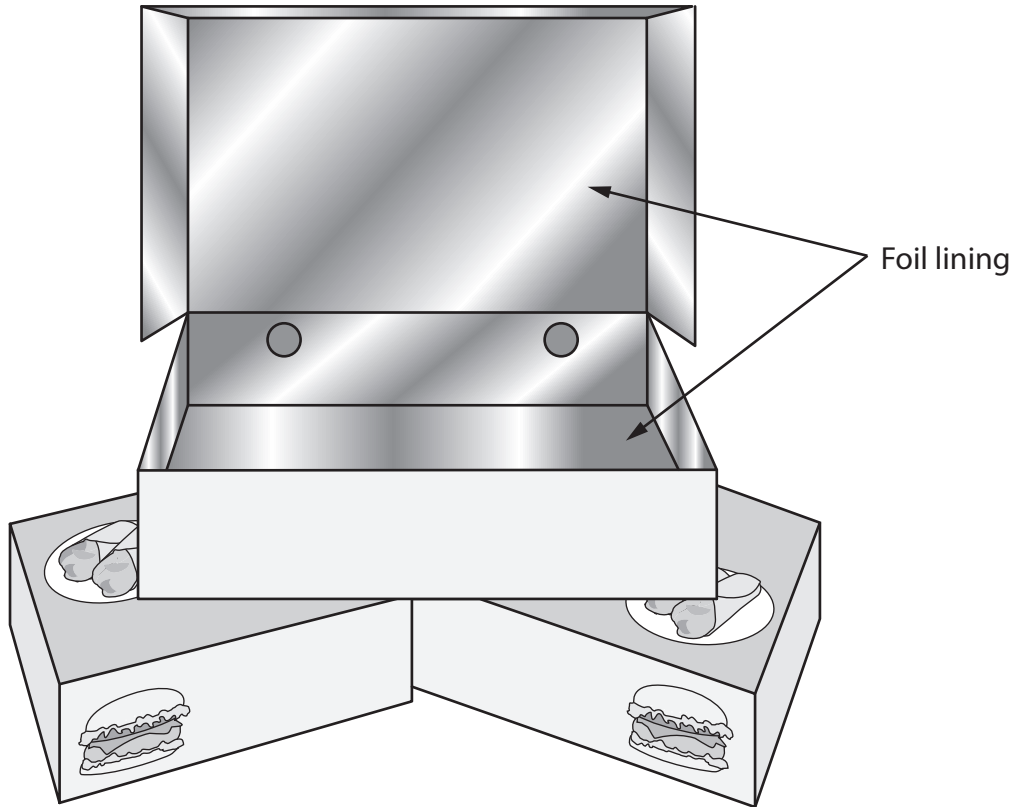

Figure 15

Manufacturing takeaway food boxes from foil-lined board is cost effective.

(a) Explain **one other** benefit of manufacturing the takeaway food boxes from foil-lined board.

(2)

.....

.....

.....

.....

(b) Explain **one** cost factor that will have been considered when selecting foil-lined board as the material from which to manufacture the takeaway food boxes.

(3)

.....

.....

.....

.....



DO NOT WRITE IN THIS AREA

DO NOT WRITE IN THIS AREA

DO NOT WRITE IN THIS AREA

(c) Explain **two** quality control checks that would be carried out on the takeaway food boxes before they are allowed to leave the factory.

(4)

1

.....

.....

.....

2

.....

.....

.....



DO NOT WRITE IN THIS AREA

DO NOT WRITE IN THIS AREA

DO NOT WRITE IN THIS AREA

(Total for Question 8 = 18 marks)

**TOTAL FOR SECTION B = 60 MARKS
TOTAL FOR PAPER = 100 MARKS**



DO NOT WRITE IN THIS AREA

DO NOT WRITE IN THIS AREA

DO NOT WRITE IN THIS AREA

BLANK PAGE



P 7 1 3 7 1 A 0 3 1 3 2

DO NOT WRITE IN THIS AREA

DO NOT WRITE IN THIS AREA

DO NOT WRITE IN THIS AREA

BLANK PAGE

