

**Friday 7 June 2013 – Afternoon**

**GCSE DESIGN AND TECHNOLOGY Resistant Materials**

**A564/01** Technical Aspects of Designing and Making

Candidates answer on the Question Paper.

**OCR supplied materials:**

None

**Other materials required:**

None

**Duration:** 1 hour 15 minutes



Candidate forename		Candidate surname	
--------------------	--	-------------------	--

Centre number						Candidate number				
---------------	--	--	--	--	--	------------------	--	--	--	--

**INSTRUCTIONS TO CANDIDATES**

- Write your name, centre number and candidate number in the boxes above. Please write clearly and in capital letters.
- Use black ink. HB pencil may be used for graphs and diagrams only.
- Answer **all** the questions in Section A **and** Section B.
- Read each question carefully. Make sure you know what you have to do before starting your answer.
- Write your answer to each question in the space provided. If additional space is required, you should use the lined pages at the end of this booklet. The question number(s) must be clearly shown.
- Do **not** write in the bar codes.

**INFORMATION FOR CANDIDATES**

- The number of marks is given in brackets [ ] at the end of each question or part question.
- The total number of marks for this paper is **60**.
- All dimensions are in millimetres.
- Your Quality of Written Communication is assessed in questions marked with an asterisk (\*).
- This document consists of **16** pages. Any blank pages are indicated.

SECTION A

Answer **all** questions.

- 1 Fig. 1 shows a sign that will be positioned in a school corridor to give directions to a D&T exhibition. The sign is made from 15 thick hardwood.

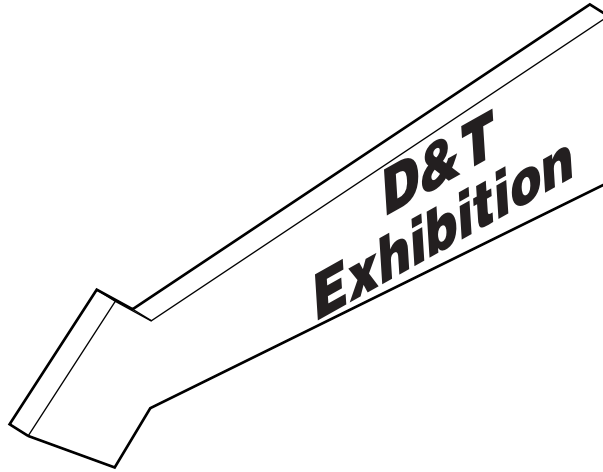

Fig. 1

- (a) Fig. 2 shows the sign marked out on a piece of hardwood ready to be cut to shape.

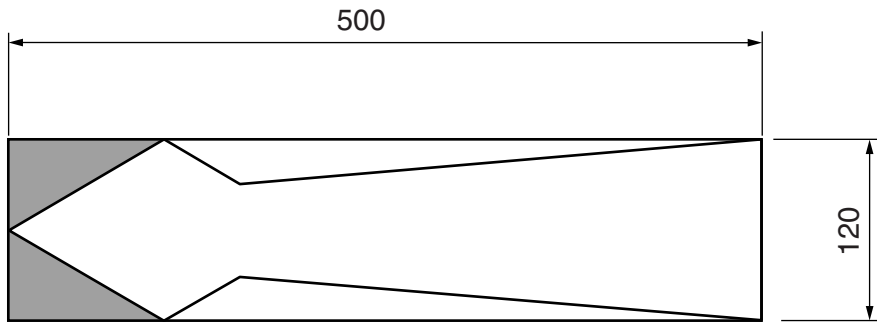

Fig. 2

Describe how the shaded areas would be removed and the shape made flat and smooth.

.....

.....

..... [2]



- 2 Fig. 3 shows a handheld game. The object of the game is to locate each of the eight balls in the eight holes. The cover and base are made from acrylic.

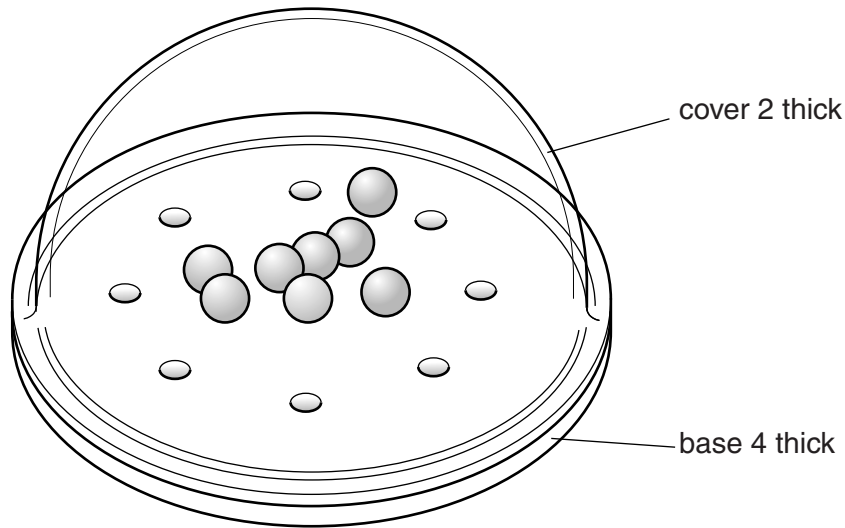

Fig. 3

- (a) Give **two** reasons why acrylic is a suitable material for the game.

1 .....

2 .....

[2]

- (b) Give **two** reasons why the acrylic base would need to be clamped in position when drilling the holes.

1 .....

2 .....

[2]

- (c) Name **two** processes that could be used to produce the cover for the game.

1 .....

2 .....

[2]

- (d) Name a solvent (glue) that could be used to join the cover to the base of the game.

..... [1]

- (e) The edges of the acrylic will be finished to a high quality shine.  
Several tools or items of equipment are used to produce a high quality finish.  
Complete the table below by describing how each tool or item of equipment is used.

Tool/Item of Equipment	How it is Used
Flat file	
Wet and dry paper	
Polishing mop	

[3]

- (f) Products such as the handheld game shown in Fig. 3 are manufactured in different parts of the world. This is known as 'globalisation'.  
Give **two** benefits of globalisation.

1 .....

2 .....

[2]

- 3 Fig. 4 shows a pen and pencil holder made from hardwood and manufactured board.

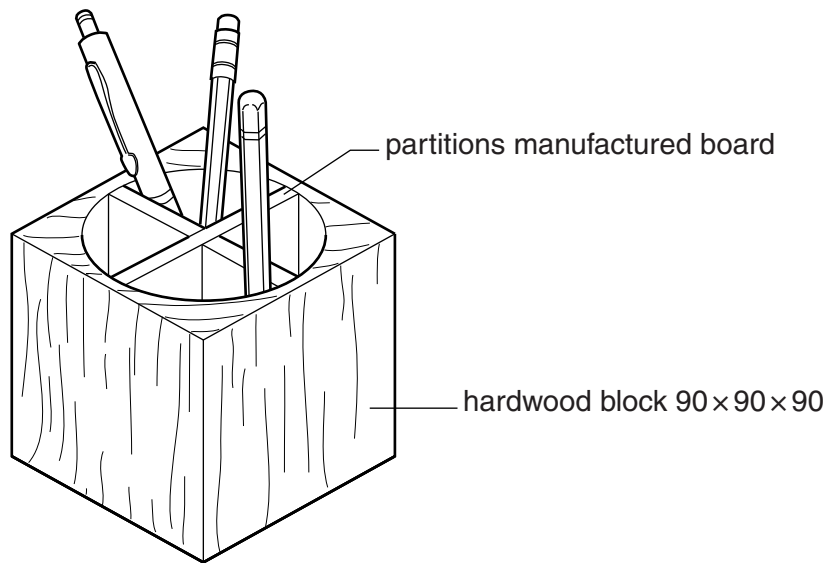

**Fig. 4**

- (a) The pen and pencil holder is made using different tools and items of equipment to complete a variety of processes.  
Complete the links below to show which tool is used to complete each process.  
Glasspaper has been done for you.

Tools/equipment	Processes
bench hook	— make rough edges flat
tenon saw	— hold material for sawing
smoothing plane	— make edges smooth
glasspaper	— cut material to size

[3]

- (b) Use sketches and notes to show how the manufactured board could be joined to make the partitions shown in Fig. 4.

[3]





**SECTION B**

Answer **all** questions.

- 4 Fig. 5 shows a wall mounted coat rack and details of one support and hook. The coat rack has a hardwood frame. The brass supports are held in holes drilled into the hardwood frame.

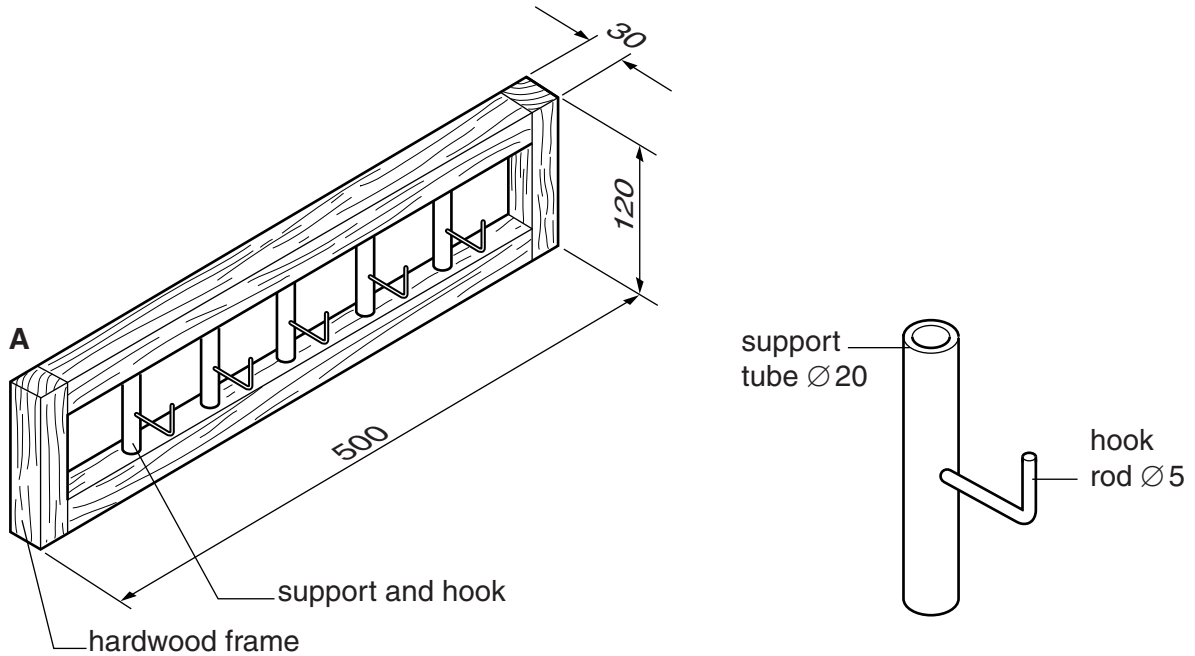

**Fig. 5**

- (a) Fig. 6 shows part of a length of brass tube from which the five supports will be cut.

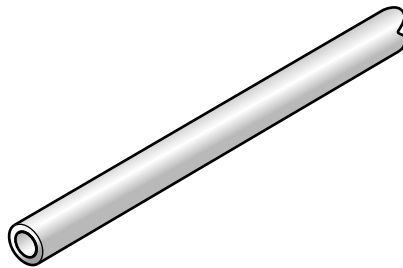

**Fig. 6**

Complete the table below by naming **one** tool or item of equipment for each process.

Process	Tool
Measure	
Mark out	
Cut to length	

[3]

(b) Give **one** reason why brass has been used to make the supports.

..... [1]

(c) (i) State **one** heat process that could be used to permanently join the brass hooks to the brass support tubes.

..... [1]

(ii) State **one** safety precaution you would need to take when carrying out a heat process in a workshop.

..... [1]

(d) Name and sketch a suitable joint, other than a butt joint, that could be used at corner **A**.

Name of joint .....

[3]

(e) Explain how the design of the coat rack could be modified so that it can be easily disassembled at the end of its useful life.

.....  
.....  
.....  
.....  
..... [3]

**5** Children learn through play.

A playgroup needs some educational toys to help children learn about different shapes.

The educational toys must:

- include a variety of shapes
- be hardwearing
- be safe for children to use

**(a)** In the space below sketch a design for **one** educational toy.

Add notes to your design to show the materials it is made from, constructional details and how it meets the specification points.

[6]



**ADDITIONAL ANSWER SPACE**

If additional answer space is required, you should use the following lined page(s). The question number(s) must be clearly shown in the margins.

This section of the page is a large, empty area of lined paper. It consists of approximately 25 horizontal dotted lines spaced evenly down the page. A solid vertical line runs down the left side of this area, creating a margin. This is intended for students to write their answers to questions that require more space than the previous page.

A series of horizontal dotted lines for writing, with a vertical solid line on the left side. The lines are evenly spaced and extend across most of the page width.

This image shows a blank sheet of handwriting practice paper. It features a vertical solid line on the left side, creating a margin. The rest of the page is filled with horizontal dotted lines, providing a guide for letter height and placement. There are 30 rows of these dotted lines in total.

**PLEASE DO NOT WRITE ON THIS PAGE**



**Copyright Information**

OCR is committed to seeking permission to reproduce all third-party content that it uses in its assessment materials. OCR has attempted to identify and contact all copyright holders whose work is used in this paper. To avoid the issue of disclosure of answer-related information to candidates, all copyright acknowledgements are reproduced in the OCR Copyright Acknowledgements Booklet. This is produced for each series of examinations and is freely available to download from our public website ([www.ocr.org.uk](http://www.ocr.org.uk)) after the live examination series.

If OCR has unwittingly failed to correctly acknowledge or clear any third-party content in this assessment material, OCR will be happy to correct its mistake at the earliest possible opportunity.

For queries or further information please contact the Copyright Team, First Floor, 9 Hills Road, Cambridge CB2 1GE.

OCR is part of the Cambridge Assessment Group; Cambridge Assessment is the brand name of University of Cambridge Local Examinations Syndicate (UCLES), which is itself a department of the University of Cambridge.