

OCR

Oxford Cambridge and RSA

Tuesday 19 June 2018 – Morning

GCSE DESIGN AND TECHNOLOGY Graphics

A535/01 Sustainability and Technical Aspects of Designing and Making

Candidates answer on the Question Paper.

OCR supplied materials:

None

Other materials required:

None

Duration: 1 hour 30 minutes



Candidate forename		Candidate surname	
-----------------------	--	----------------------	--

Centre number						Candidate number				
---------------	--	--	--	--	--	------------------	--	--	--	--

INSTRUCTIONS TO CANDIDATES

- Write your name, centre number and candidate number in the boxes above. Please write clearly and in capital letters.
- Use black ink. HB pencil may be used for graphs and diagrams only.
- Answer **all** the questions in Section A and Section B.
- Read each question carefully. Make sure you know what you have to do before starting your answer.
- Write your answer to each question in the space provided. If additional space is required, you should use the lined page(s) at the end of this booklet. The question number(s) must be clearly shown.
- Do **not** write in the barcodes.

INFORMATION FOR CANDIDATES

- The number of marks is given in brackets [] at the end of each question or part question.
- The total number of marks for this paper is **80**.
- Your quality of written communication is assessed in questions marked with an asterisk (*).
- This document consists of **20** pages. Any blank pages are indicated.

SECTION A

Answer **all** the questions.

You are advised to spend 40 minutes on this section.

On questions 1–5 **circle** your answer.

1 CFCs are known to cause damage to:

(a) The ozone layer

(b) Forests and woodlands

(c) Rivers and seas

(d) The Earth's core

[1]

2 The symbol shown means recyclable:

(a) Steel

(b) Paper

(c) Glass

(d) Electrical items



[1]

3 To rethink means:

(a) Not buying the product

(b) Repairing a product

(c) Manufacturing a product

(d) Changing the design

[1]

4 Photochromic ink can change colour when it is exposed to:

(a) Heat

(b) Light

(c) Electricity

(d) Water

[1]

- 5 The measuring of carbon emissions is called:
- (a) A carbon footprint
 (b) Carbon Offsetting
 (c) Balancing carbon
 (d) A toxic footprint [1]
- 6 Give **one** suggestion for an alternative use for an unplayable compact disc (CD).
 [1]
- 7 Solar energy is a type of renewable energy.
 Name **one** other.
 [1]
- 8 Discarded plastic bags can be harmful to the environment.
 Give **one** reason why.
 [1]
- 9 Children's outdoor playground areas need a safe floor covering.
 Name **one** suitable product or material that could be recycled and used for covering an outdoor playground area.
 [1]
- 10 Give **one** social, moral or cultural issue that should be considered when designing products.
 [1]

Decide whether the statements below are **true** or **false**.

Tick (✓) the box to show your answer.

- | | True | False | |
|---|--------------------------|--------------------------|-----|
| 11 Consumers should refuse to buy products made from unsustainable sources. | <input type="checkbox"/> | <input type="checkbox"/> | [1] |
| 12 Primary recycling is reusing a product for its original purpose. | <input type="checkbox"/> | <input type="checkbox"/> | [1] |
| 13 Instructions on packaging should be printed only in English. | <input type="checkbox"/> | <input type="checkbox"/> | [1] |
| 14 Batteries should be disposed of separately to household waste. | <input type="checkbox"/> | <input type="checkbox"/> | [1] |
| 15 COSHH regulations are designed to protect factory workers. | <input type="checkbox"/> | <input type="checkbox"/> | [1] |

16 Fig. 1 shows a popcorn bucket.

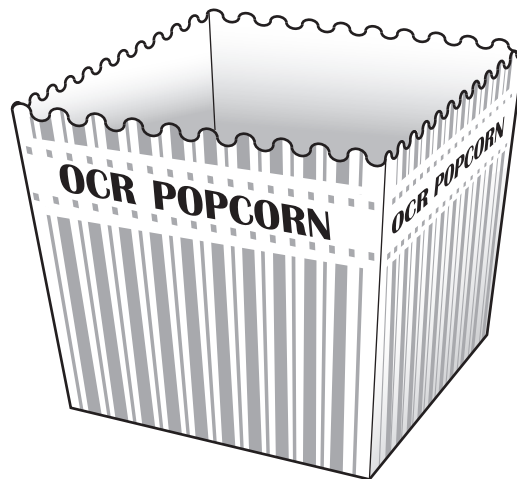

Fig. 1

(a) (i) Name **one** suitable material for the popcorn bucket shown in Fig. 1.

..... [1]

(ii) State **one** reason for your choice of material.

..... [1]

(b) The manufacturer wants to make the popcorn bucket shown in Fig. 1 more comfortable and easier to hold for the consumer.

In the table below tick (✓) the correct name for making products fit better with the human form.

Aesthetics	Anthropometrics	Ergonomics

[1]

- (c) Sketch **one** modification to the popcorn bucket shown in Fig. 1 that would make it more comfortable and easier to use.

[3]

(d) Complete the chart to show the **life cycle** of the popcorn bucket.

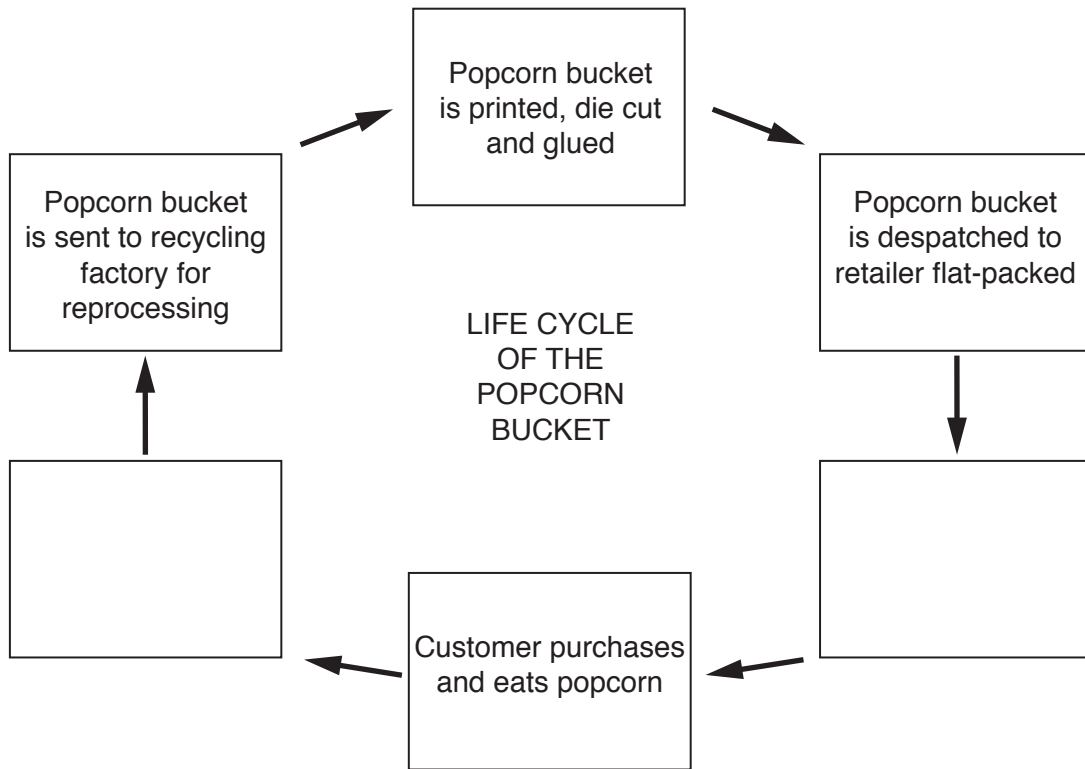

[2]

(e) The manufacturer of the popcorn bucket wants to become involved in carbon offsetting. Explain carbon offsetting and give **one** example.

Explanation

.....

Example

.....

[2]

- (f) A logo is needed to show that the manufacturer supports carbon offsetting.

In the space below, use sketches and notes to show a suitable design for the logo.
The design must:

- show carbon offsetting
- be easily understood
- use no words
- be contained within a suitable shape.

[4]

SECTION B

Answer **all** the questions.

You are advised to spend 50 minutes on this section.

17 Fig. 2 shows a sign made from foamboard.



Fig. 2

(a) Complete the letters of the word 'FREE' on the grid below.

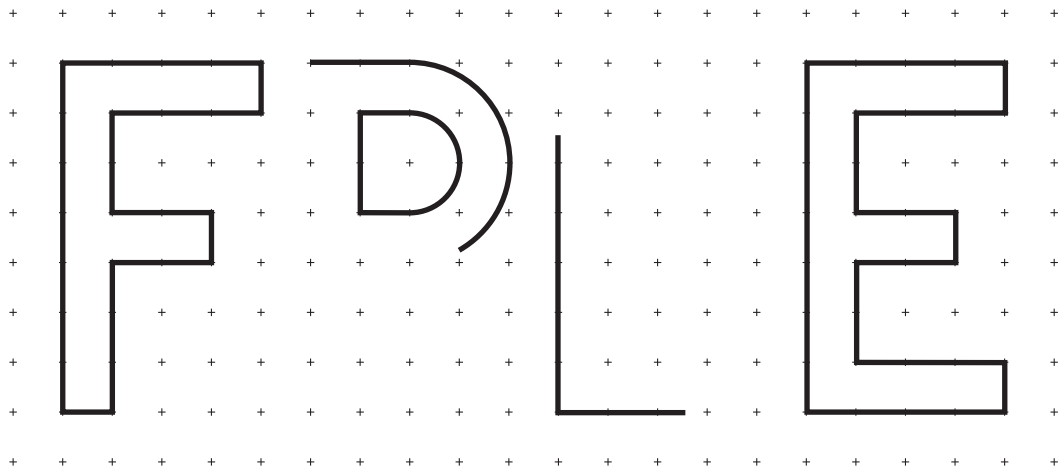

[2]

(b) State **one** reason why foamboard has been used for the sign.

..... [1]

(c) Fig. 3 shows a section through a piece of foamboard.
Complete the diagram by naming the parts arrowed.

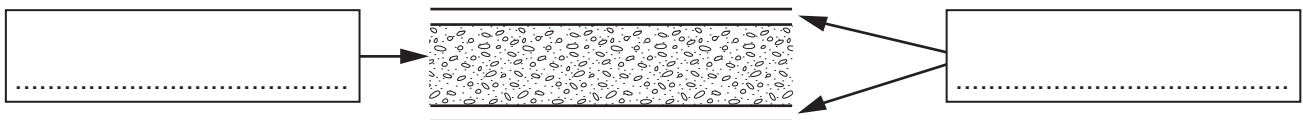
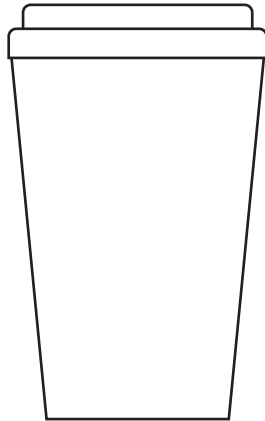

Fig. 3

[2]

Turn over

- (d) The designer of the sign wants the cup to look more three-dimensional and rounded like a real cup.
On the drawing below apply shading to make the cup look more realistic.



[2]

- (e) The base of the sign is folded backwards as shown in Fig. 4.

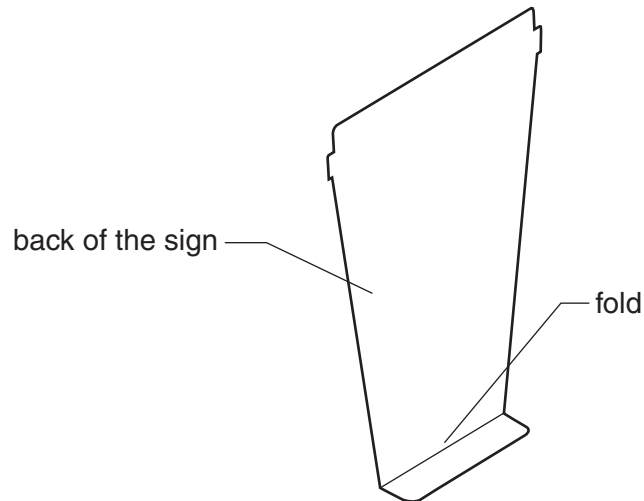

Fig. 4

Use sketches and notes to show how you would make the fold in the foamboard.

[2]

- (f) A stand is required to fit behind the sign to make it more stable when in use.

Use sketches and notes to show **one** idea for a stand.

The stand must:

- be made from foamboard
- hold the sign securely in an upright position
- slot together
- attach to the back of the sign.

[6]

18 Fig. 5 shows a card package for an energy saving light bulb.

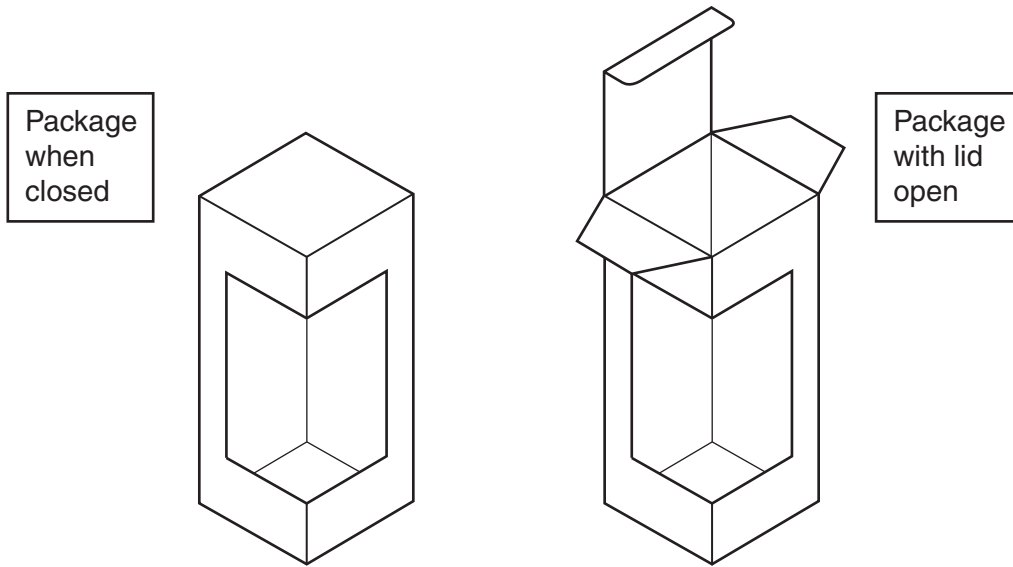
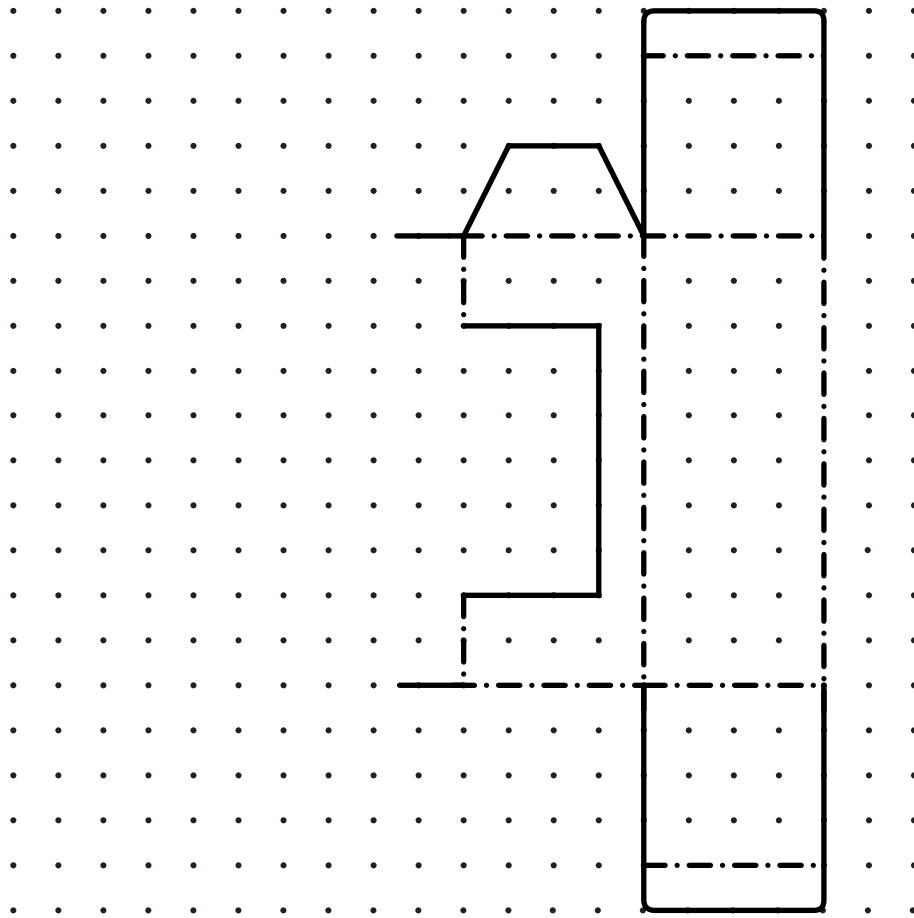

Fig. 5

(a) Complete the development (net) below of the light bulb package shown in Fig. 5.



[5]

- (b) The main colour of the package will be green.
Give **one** reason why green is used on the packaging of many energy saving products.

..... [1]

- (c) A styrofoam insert fits inside the base of the package to hold the bulb upright.
The insert is shown in Fig. 6.

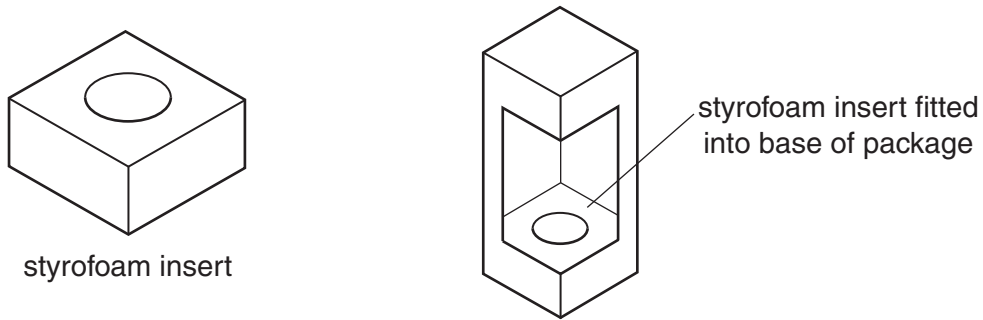
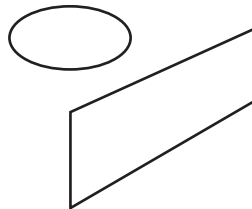

Fig. 6

Complete the two-point perspective view below of the insert in Fig. 6.

V.P.
x

V.P.
x



[3]

- (d) The inserts are manufactured from a block of styrofoam using a CNC machine.
State a suitable CNC machine for making the inserts.

..... [1]

(e) A datasheet on the styrofoam is provided by the supplier for the manufacturer of the insert.

(i) Give **one** piece of information about the styrofoam that would be on the datasheet.

..... [1]

(ii) Explain why it is important for the manufacturer of the insert to know this information.

.....
.....
..... [2]

(f) The energy saving light bulb is manufactured using nanotechnology.
Explain the meaning of the term nanotechnology.

.....
.....
..... [2]

19 Fig. 7 shows a box used for transporting small pets. The box is made from corrugated card.

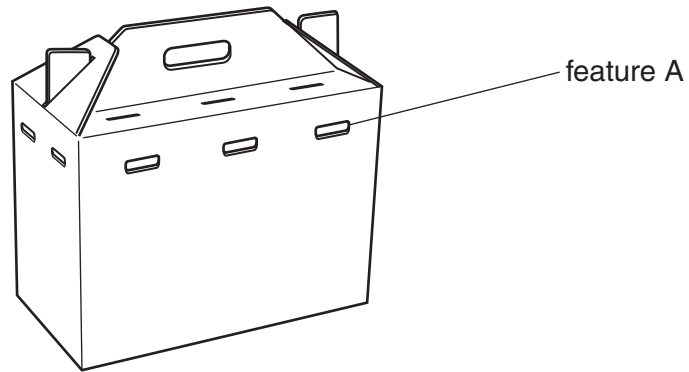

Fig. 7

(a) State the purpose of feature A.

..... [1]

(b) The box is to be produced in quantities of 5000.
State **one** suitable method of cutting out the nets for the box.

..... [1]

- (c) Fig. 8 shows the vet’s logo design that will be printed onto the side of the box. The design has been produced using desktop publishing and saved as a bitmap image.



Fig. 8

Explain **two** disadvantages of using bitmap images.

1.....

 2.....

 [4]

- (d) State **one** suitable method of printing the logo design onto the corrugated cardboard box. [1]

- (e) The same logo will be used on the OCR Vets business card.
 State **one** purpose of the business card. [1]

(f) In the table below tick (✓) the most appropriate size for the business card.

297 mm x 210 mm	150 mm x 105 mm	85 mm x 55 mm	30 mm x 15 mm

[1]

ADDITIONAL ANSWER SPACE

If additional space is required, you should use the following lined page(s). The question number(s) must be clearly shown in the margin(s).

A large area of lined paper for writing, consisting of 25 horizontal dotted lines. A solid vertical line runs down the left side of the page, creating a margin. The rest of the page is blank.

A large area of the page is reserved for writing, featuring a vertical solid line on the left side and horizontal dotted lines extending across the page.



Copyright Information

OCR is committed to seeking permission to reproduce all third-party content that it uses in its assessment materials. OCR has attempted to identify and contact all copyright holders whose work is used in this paper. To avoid the issue of disclosure of answer-related information to candidates, all copyright acknowledgements are reproduced in the OCR Copyright Acknowledgements Booklet. This is produced for each series of examinations and is freely available to download from our public website (www.ocr.org.uk) after the live examination series.

If OCR has unwittingly failed to correctly acknowledge or clear any third-party content in this assessment material, OCR will be happy to correct its mistake at the earliest possible opportunity.

For queries or further information please contact the Copyright Team, First Floor, 9 Hills Road, Cambridge CB2 1GE.

OCR is part of the Cambridge Assessment Group; Cambridge Assessment is the brand name of University of Cambridge Local Examinations Syndicate (UCLES), which is itself a department of the University of Cambridge.